

TEHNIČKE KARAKTERISTIKE

- Max. temperatura pumpanog medija 40°C
- Zaštita motora IP68
- Izolacija: Class F
- Jednofazni model sa plovkom , strujnom termičkom zaštitom + MAXI. PROTECTION SWITCH >>>

<http://pumpe.hr/ovdje-klikni-za-opis/maxi-protection-switch>



KPL. INOX PUMPA

MATERIJALI IZRADE KPL. INOX PUMPE

- Tijelo pumpe: INOX 304
- Kućište motora: INOX 304
- Duple mehaničke brtve unutar komore izrađene od vrhunskih materijala koje osiguravaju dugi vijek rada
- Materijali specijalnih brtvi silicij/karbid/viton x 2 (jedinstveno na tržištu jer većina ostalih proizvođača ugrađuju jednu mehaničku brtvu te eventualno obične semeringe)
- Osovina : INOX 430
- Rotor pumpe (lopatica) : INOX 304 tipa > vortex antiblokirajući

UPOTREBA

- Pumpanje čiste , muljne te otpadne fekalne vode

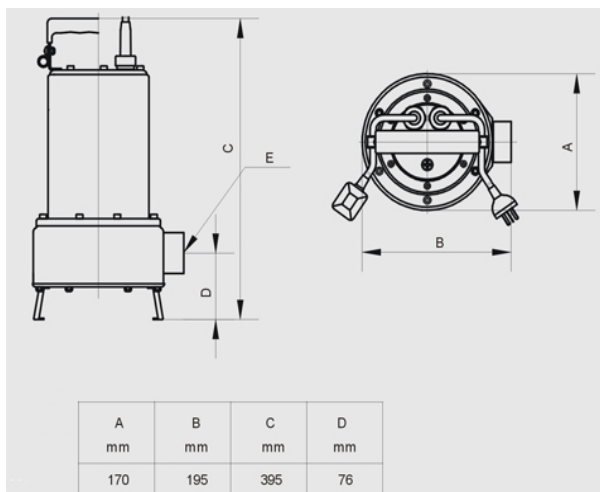

VORTEX ROTOR ANTIBLOCKING SYSTEM

Professional



PERFORMANSE

RPM 2900 - HZ 50

TIP	SNAGA		A	VOLTA	KAPACITET (PROTOK)								KABEL	PRIKLJUČAK IZLAZ	MAX. KRUTE ČESTICE	KG
					m³/h	0	6	12	18	24	30	42				
					l/min	0	100	200	300	400	500	700				
AQUAPIU 150M	HP	Kw	7	230 - 50 Hz	VISINA DIZANJA (PUMPANJA)								H 07 RN-F	1" 1/2	Ø 38 mm	10
					H m	12,5	10,5	8,5	5,5	2	-	-				

KRATKI VIDEO O PRINCIPU RADA HIDRAULIKE OVE PUMPE MOŽETE VIDJETI KLIKOM NA DOLJE NAVEDENI LINK :

<http://pumpe.hr/opcenito-o-pumpama/hidraulika-potopnih-pumpi/447>



Vaš život , naša kvaliteta , diljem svijeta